

The MBI6655 Application Note

Overview

The MBI6655 is a constant current, step-down DC/DC converter with high efficiency, and is designed to drive high power LED in constant current. The Hysteretic PFM control scheme enhances the efficiency at light load condition. The output current can be programmed by an external resistor, and the DIM pin provides another method to adjust the output current by connecting a PWM signal. The embedded peak current limit protects LED from being damaged by large current. The MBI6655 also features Over Temperature Protection, Open Circuit Protection and Short Circuit Protection to protect IC from being damaged.

With only 4 external components required to achieve power conversion, the MBI6655's built-in MOSFET allows the use in space sensitive application. MBI6655 provides two packages SOP8 and SOT89. The SOP8 package offers a thermal pad to enhance the heat dissipation. And tiny package, SOT89, saves space in application.

Hysteretic PFM Control Scheme

The key feature of the MBI6655 is its hysteretic pulse-frequency-modulation (PFM) control scheme with high side current limit. When the power is on, Voltage of Rsen, V_{SEN} , is lower than V_H (0.115V), which causes the internal MOSFET of the MBI6655 to turn on and V_{SEN} increase with I_L . Until V_{SEN} is equal to V_H , the MOSFET turns off, and V_{SEN} decreases with I_L . When V_{SEN} decreases and is down to V_L (0.085V), the internal MOSFET turns on again, and the actions above repeat. However, the inductor current will always work on Continuous Current Mode (CCM) due to the character of the Hysteretic PFM control. This is helpful in terms of reducing the LED ripple current. Figure 1 below demonstrates the application circuit of the MBI6655, and Figure 2 shows the waveform of the Hysteretic PFM control scheme.

The switching frequency of this control scheme varies according to the output loading; the heavier the loading, the lower switching frequency will be. When it is under the same loading condition, the larger inductance will result the lower switching frequency. The lowest switching frequency is limited to 40 kHz to avoid audio noise. The high side current limit allows users to choose a smaller size and offers lower power consumption resistor than that in low side current limit unit. As a result, it is helpful in terms of space and cost saving considerations.

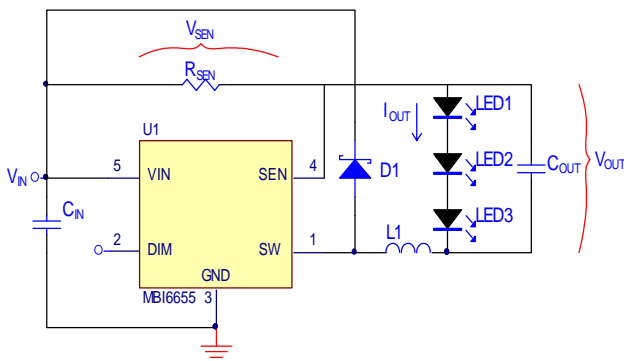

Figure 1. Application circuit of MBI6655

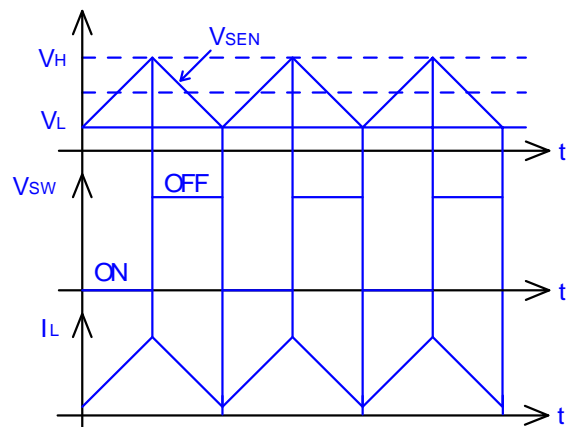

Figure 2. Waveform of hysteretic PFM control scheme

Peak Current Limit

For normal operation, a dropout voltage between input and output voltage is desired. **As the input voltage becomes lower than the minimum input voltage—which is the sum of the dropout voltages on each external components and the total forward voltage of the cascaded LEDs, the internal MOSFET of the MBI6655 will always turn on, and the maximum LED current is limited to 1.15 times of the expect current.** On the contrary, if the input voltage is larger than the minimum input voltage, or if the total forward voltage of the cascaded LEDs decreases due to LED's rising temperature, the output current will recover to the preset.

Dimming

The LED current can be adjusted by connecting a PWM signal to DIM pin of the MBI6655. When a low level signal (lower than 0.5V) appears at the DIM pin, the internal MOSFET turns off and shuts the LED current, and vice versa. A high level voltage larger than 3.0V will turn-on the MOSFET. The larger duty cycle of PWM signal will result higher LED current. To avoid the audio noise caused by low PWM frequency, a smaller inductor value can be considered, but it is a trade-off with the line/load regulation. For linear dimming, the maximum PWM frequency applied to DIM pin is 1kHz.

Over Temperature Protection

The MBI6655 offers an over temperature protection, and it starts at 165°C. As junction temperature exceeds over 165°C, the internal MOSFET will turn off and shut down the LED current. Thus, the junction temperature will start to decrease. As the junction temperature is below 135°C, the internal MOSFET will turn on again and recover switching.

Over Current Protection

The MBI6655 offers a over current protection, and the output current exceeds over 1.8A. As the MBI6655 of output current exceeds over 1.8A, the internal MOSFET will turn off and shut down the LED current. When the function is activated, it will not be removed until power reset action is taken.

Open Circuit Protection

The MBI6655 has a built-in open circuit protection. The internal MOSFET stops switching and remains at turn off state. Thus, the LED current is zero.

Short Circuit Protection

The MBI6655 offers a short circuit protection. As LED is shorted, the output voltage will drop to zero, but the internal MOSFET will keep on switching and the output current will be the preset value. In multi-LED cascaded application, if one or more than one LEDs are shorted, the output voltage across the LEDs will be decreased, and yet the LED current still maintains its preset value.

Design Consideration

Switching Frequency

The switching frequency is related to efficiency (better at low frequency), components size/cost (smaller/cheaper at high frequency), and the amplitude of output ripple voltage and current (smaller at high frequency). The slower switching frequency comes from the large value of inductor. On many applications, the sensitivity of EMI limits the switching frequency of MBI6655. The switching frequency can be ranged from 40kHz to 2MHz (as inductor equals to 68uH).

LED Ripple Current

A LED constant current driver, such as MBI6655, is designed to control the current through the cascaded LED, but the voltage across it. Higher LED ripple current allows the use of smaller inductance, smaller output capacitance and even without an output capacitor. The advantages of higher LED ripple current are to minimize PCB size and reduce cost because of no output capacitor. Lower LED ripple current requires larger inductance, and output capacitor. The advantages of lower LED ripple current are to extend LED life time and to reduce heat of LED. The recommended ripple current is from 5% to 20% of normal LED current.

Components Selection

Output Current Setting

The output current can be programmed by an external resistor, the relationship between I_{OUT} and R_{SEN} is

$$R_{SEN} = (V_{SEN} / I_{OUT}) \quad (1)$$

where R_{SEN} is current sense resistor, which is connected between VIN and SEN pin of the MBI6655, 1% tolerance is recommended for better output current accuracy, and V_{SEN} is the voltage across R_{SEN} . The sustaining power dissipation on R_{SEN} , P_{RSEN} , is

$$P_{RSEN} = (V_{SEN}^2 / R_{SEN}) \quad (2)$$

Inductor Selection

The inductance is determined by two factors: the switching frequency and the inductor ripple current. The calculation of the inductance, L1, can be described as

$$L1 > (V_{IN} - V_{OUT} - V_{SEN} - (R_{ds(on)} \times I_{OUT})) \times \frac{D}{f_{SW} \times \Delta I_L} \quad (3)$$

where

$R_{ds(on)}$ is the on-resistor of internal MOSFET of MBI6655. The typical is 0.3Ω at 12V_{IN}.

D is the duty cycle of MBI6655, $D = V_{OUT} / V_{IN}$.

f_{SW} is the switching frequency of MBI6655.

ΔI_L is the ripple current of inductor, $\Delta I_L = (1.15 \times I_{OUT}) - (0.85 \times I_{OUT}) = 0.3 \times I_{OUT}$.

In selecting an inductor, the inductance is not the only factor to affect the performance of module, but the saturation current also needs to be considered. In general, it is recommended to choose an inductor with 1.5 times of LED current as the saturation current. Also, the larger inductance gains the better line/load regulation and efficiency. However, with the same inductor size, the inductance and saturation current becomes a trade-off. An inductor with shielding is recommended to reduce the EMI interference, but this is another trade-off with heat dissipation.

Schottky Diode Selection

The MBI6655 needs a flywheel diode, D1, to carry the inductor current when the MOSFET is off. The recommended flywheel diode is schottky diode with low forward voltage for better efficiency. Two factors determine the selection of schottky diode. One is the maximum reverse voltage, and the recommended rated voltage of the reverse voltage is at least 1.5 times of input voltage. The other is the maximum forward current, which works when the MOSFET is off. The recommended forward current is 1.5 times of output current. Since the switching characteristics of schottky diode degrades with the rising temperature, the recommended operating temperature is 85°C to prevent MBI6655 from being damaged by large leakage current, which caused by the schottky diode.

Minimum Input Voltage

The minimum input voltage is the sum of the voltage drops on R_{SEN} , R_S , DCR of L1, $R_{ds(on)}$ of internal MOSFET and the total forward voltage of LEDs. The dynamic resistance of LED, R_S , is the inverse of the slope in linear forward voltage model for LED. This electrical characteristic can be provided by LED

manufacturers. **As the input voltage is smaller than minimum input voltage, which is pointed out by MBI6655 Design Tool, the output current will be larger than the preset output current, and is limited to 1.15 times of preset one.** The equivalent impedance of the MBI6655 application circuit is shown as in Figure 3. To calculate these voltage drops, the peak LED current must be defined first. As previously mentioned, the peak current is 1.15 times of the preset current, and then the voltage drops on each component can be calculated as below

$$V_{R_{SEN}} = R_{SEN} \times I_{OUT} \times 1.15 \quad (4)$$

$$V_{RS} = R_S \times I_{OUT} \times 1.15 \times n, \text{ where } n \text{ is the amount of LED.} \quad (5)$$

$$V_{MOSFET} = R_{ds(on)} \times I_{OUT} \times 1.15 \quad (6)$$

$$V_{L1} = DCR \times I_{OUT} \times 1.15 \quad (7)$$

Thus, the minimum input voltage ($V_{IN, MIN}$) can be defined as

$$V_{IN, MIN} = V_{R_{SEN}} + V_{RS} + V_{MOSFET} + V_{L1} + V_{F, LED} \quad (8)$$

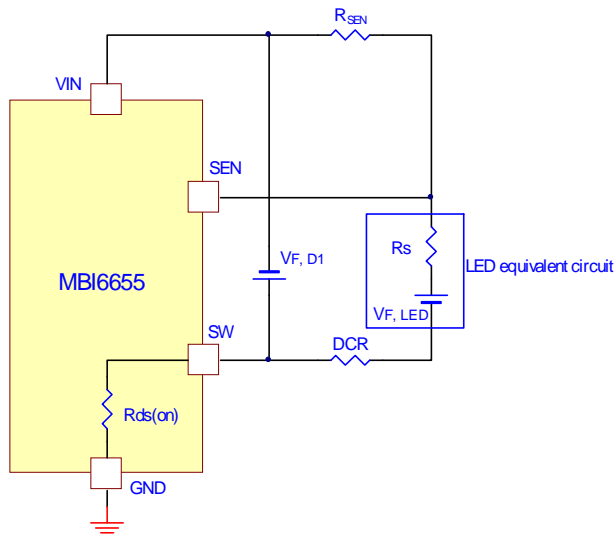

Figure 3. The equivalent impedance of MBI6655 application circuit

Input Capacitor Selection

The input capacitor, C_{IN} , supplies pulses of current for the MBI6655 when the MOSFET is on, and C_{IN} is charged by input voltage when the MOSFET is off. As the input voltage is lower than the tolerable input voltage, the internal MOSFET of the MBI6655 becomes constantly “on”, and the LED current is limited to 1.15 times of normal current. The recommended value of input capacitor is 10uF for stabilizing the lighting system. The rated voltage of input capacitor should be at least 1.5 times of input voltage.

For system stability, placing the C_{IN} to the VIN pin of MBI6655 as close as possible is recommended. However, the PCB size may limit this requirement. Therefore, to avoid the noise interference, a bypass ceramic capacitor, which ranges is from 0.1uF to 1uF and is parallel with the VIN and GND pins of MBI6655 is recommended. The rated voltage of bypass capacitor should be at least 1.5 times of input voltage.

The rated voltage and capacitance are not the only concern in selecting capacitors, but also the maximum ripple current. If the specification of maximum ripple current is smaller than the produced, the capacitor may

be damaged and furthermore damage IC. In general, the ripple current is related to the inductor ripple current. The specification of maximum ripple current of capacitor should be larger than 1.3 times of the inductor ripple current.

A tantalum or ceramic capacitor can be used as an input capacitor. The advantages of tantalum capacitor are high capacitance and low ESR. The advantages of ceramic capacitor are high frequency characteristic, small size and low cost. In compare with the tantalum capacitor, the ceramic capacitor features the lower ESR, so it is not recommended to use in hot plugging application. Users can choose an appropriate one for applications.

Output Capacitor Selection (Optional)

For reducing LED ripple current, a capacitor parallels with the cascaded LED is recommended. Proportionally, the higher capacitor value results the lower LED ripple current. Normally, a 10uF output capacitor with low ESR is desired, and the recommended rated voltage of the output capacitor is 1.5 times of total LED forward voltage. Without this paralleled capacitor, the LED ripple current is equal to the inductor current, 0.3 times of LED current. Note that the output capacitor can affect neither the switching frequency nor efficiency. The material of output capacitor can be tantalum or ceramic unit. For better stability over temperature, the output/input capacitor with X7R or X5R dielectric is recommended. A ceramic capacitor with Y5V dielectric is not recommended in this application due to bad temperature compensation.

Estimated Efficiency

To estimate the efficiency, the power consumption on each current carrying element must be calculated and summed up. The efficiency (η) can be described as

$$\eta = \frac{P_{OUT}}{P_{OUT} + P_{LOSS}} \quad (9)$$

where

P_{OUT} is the power consumption of LED. The calculation is

$$P_{OUT} = V_{OUT} \times I_{OUT} \quad (10)$$

The power loss (P_{LOSS}) in step-down DC/DC converter includes

$$P_{LOSS} = P_C + P_{SW} + P_{IC} + P_L + P_{D1} + P_{RSEN} \quad (11)$$

where

P_C is conduction loss during the internal MOSFET turns on, $P_C = I_{OUT}^2 \times R_{ds(on)} \times D$.

P_{SW} is the switching loss of the MOSFET during switching, $P_{SW} = V_{IN} \times I_{OUT} \times (t_r + t_f) \times f_{SW}$. t_r and t_f are the rising and falling times of the switch signal.

P_{IC} is the power consumption of MBI6655, $P_{IC} = I_{DD} \times V_{IN}$. I_{DD} is the supply current of MBI6655, normally is 1mA.

P_L is the inductor loss caused by the DC resistance (DCR) of inductor, $P_L = I_{OUT}^2 \times DCR$.

P_{D1} is the power loss of schottky diode, $P_{D1} = V_{F,D1} \times I_{OUT} \times (1-D)$, $V_{F,D1}$ is the forward voltage of schottky diode.

P_{RSEN} is the power loss on R_{SEN} , $P_{RSEN} = V_{SEN} \times I_{OUT}$.

Estimated Junction Temperature

The power losses will cause temperature rising on the MBI6655 body. When the junction temperature (T_J) reaches 165°C , the MBI6655 will enter thermal protection model and shut the LED current off. Thus, it's important for designers to recognize the relationship between power losses and rising temperature. The relationship can be described as

$$T_J = T_A + P_{\text{LOSS, IC}} \times R_{\text{th, JA}} \quad (12)$$

where

T_A is the ambient temperature.

$P_{\text{LOSS, IC}}$ is the power loss in MBI6655, $P_{\text{LOSS, IC}} = P_C + P_{\text{SW}} + P_{\text{IC}}$.

$R_{\text{th, JA}}$ is thermal resistor of MBI6655 from junction to ambient.

Design Example

For lighting 2 pieces of high power white LEDs, the forward voltage of LED is $3.72\text{V}/\text{pcs}$. The desired LED current is 350mA , input voltage is 12V . To consider the PCB size, switching frequency f_{SW} sets 1MHz . Please calculate the required components. (The package of MBI6655 is SOT89, and the used LED is from LUXEON, LXK2-PW14-U00, with 0.6Ω dynamic resistance)

I_{OUT} , R_{SEN} and D

The R_{SEN} can be calculated by (1), $R_{\text{SEN}} = 0.1\text{V} / 0.35\text{A} = 0.286\Omega$. Here select a 0.3Ω resistor to be R_{SEN} and the LED current would be $I_{\text{OUT}} = 0.1\text{V} / 0.3\Omega = 333\text{mA}$. The sustaining power dissipation is $P_{\text{RSEN}} = 0.1\text{V}^2 / 0.3\Omega = 0.033\text{W}$. Thus, a 1%, 0.3Ω resistor with 0.125W power dissipation is recommended.

The duty cycle of MBI6655 is $D = (3.72\text{V} \times 2) / 12\text{V} = 0.62$.

Inductor Selection

From (3), the inductor, $L1$, can be chosen

$$L1 > [12\text{V} - (3.72 \times 2) - 0.1\text{V} - (0.3\Omega \times 0.333\text{A})] \times [0.62 / (1\text{MHz} \times 0.3 \times 0.333\text{A})] = 27.06\mu\text{H}$$

Thus, the recommended inductor is $33\mu\text{H}$ with 0.75A saturation current and 0.16Ω DCR. And since the inductor is changed to $33\mu\text{H}$, the switching frequency should be modified as

$$f_{\text{SW}} = [12\text{V} - (3.72 \times 2) - 0.1\text{V} - (0.3\Omega \times 0.333\text{A})] \times [0.62 / (33\mu\text{H} \times 0.3 \times 0.333\text{A})] = 819.15\text{kHz}$$

Schottky Selection

In this application, the recommended selection in the schottky diode is SSCD102 with 20V reverse voltage, 1A forward current, and 0.5V forward voltage as its maximum.

Minimum Input Voltage

The minimum input voltage is the sum of voltage drops on each current carrying element and the forward voltage of LEDs during MOSFET turns on. The voltage drops on each component are

$$V_{R_{SEN}} = 0.1V \times 1.15 = 0.115V$$

$$V_{R_S} = 0.6\Omega \times 0.333A \times 1.15 \times 2 = 0.46V$$

$$V_{MOSFET} = 0.3\Omega \times 0.333A \times 1.15 = 0.114V$$

$$V_{L1} = 0.16\Omega \times 0.333A \times 1.15 = 0.061V$$

$$\text{Thus the minimum input voltage is } V_{IN, MIN} = 0.115V + 0.46V + 0.114V + 0.061V + 7.44 = 8.19V$$

Input Capacitor Selection

To handle this system safely, a 10uF tantalum capacitor with 16V rated voltage is recommended.

Bypass Capacitor Selection

To avoid the noise interference, a 0.1uF ceramic capacitor with 16V rated voltage is recommended to be the by pass capacitor.

Output Capacitor Selection

For LED ripple current reduction, an output capacitor parallels with LED array is required. In this example, the recommended output capacitor is a ceramic unit with 10uF and the rated voltage is 10V.

Efficiency

The power consumption on each component can be calculated as

$$P_{OUT} = V_{OUT} \times I_{OUT} = 2 \times 3.72V \times 0.333A = 2.48W$$

$$P_C = I_{OUT}^2 \times R_{ds(on)} \times D = (0.333A)^2 \times 0.3\Omega \times 0.62 = 20.67mW$$

$$P_{SW} = V_{IN} \times I_{OUT} \times (t_r + t_f) \times f_{SW} = 12V \times 0.333A \times (40ns) \times 819.15kHz = 131.06mW$$

$$P_{IC} = I_{DD} \times V_{IN} = 1mA \times 12V = 12mW$$

$$P_L = I_{OUT}^2 \times DCR = (0.333A)^2 \times 0.16\Omega = 17.78mW$$

$$P_{D1} = V_{F, D1} \times I_{OUT} \times (1-D) = 0.5V \times 0.333A \times (1-0.62) = 63.33mW$$

$$P_{RSEN} = V_{SEN} \times I_{OUT} = 0.1V \times 0.333A = 33.33mW$$

$$P_{LOSS} = P_C + P_{SW} + P_{IC} + P_L + P_{D1} + P_{RSEN} = 278.18mW$$

Thus, the efficiency in this application is

$$\eta = \frac{P_{OUT}}{P_{OUT} + P_{LOSS}} = \frac{2.48W}{2.48W + 278.18mW} \times 100\% = 89.91\%$$

Raised Junction Temperature

The raised junction temperature can be estimated by

$$T_J = T_A + P_{LOSS, IC} \times R_{th, JA} = 25^\circ\text{C} + (20.67\text{mW} + 131.06\text{mW} + 12\text{mW}) \times 70.8^\circ\text{C/W} = 36.59^\circ\text{C}.$$

Followings show the application circuit and BOM for reference.

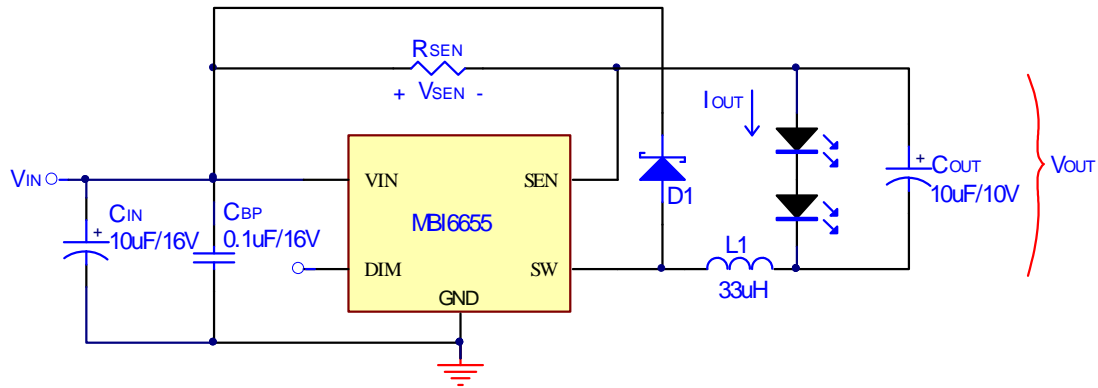

Figure 4 The application circuit of design example

Table 1 The BOM of design example

Designator	Device Value	Description	Vendor	Contact Window
C _{IN}	10uF/16V	WF series electrolytic capacitor, 5x11, DIP	AVX	+886-3-594-1818, ext.68
C _{OUT}	10uF/10V	WF series electrolytic capacitor, 5x11, DIP	AVX	+886-3-594-1818, ext.68
C _{BP}	0.1uF/16V	SMD ceramic capacitor, 0603, X5R	AVX	+886-3-594-1818, ext.68
D1	20V/1A	S5CD102, Surface Mount Schottky Barrier Rectifier	ZOEWIE	+886-2-2219-5533, ext.216
L1	33uH	GSDS106C2-330M	GANG SONG	+886-2-2218-2357
R _{SEN}	0.1Ω	SMD Resistor, 1206	Viking	+886-3-597-2931, ext.5818
U1	MBI6655GSB	Step-Down, 1A LED Driver, SOT89	MBI	+886-3-579-8934

PCB Layout Consideration

With the aim of enhancing efficiency and stabilizing the system, it is essential to keep a careful printed circuit layout. There are several notes that need to be taken.

1. Keeping a complete ground area is helpful to eliminate the switching noise.
2. Keep the IC's GND pin and the ground leads of input/output filter capacitors in less than 5mm.
3. To maximize the output power, efficiency and minimizing output ripple voltage, use a ground plane and solder the IC's GND pin directly to the ground plane.
4. To stabilize system, the heat sink of MBI6655 is recommended to connect to ground plane directly.
5. To enhance heat dissipation, the area of ground plane, which IC's heat sink is soldered on it, should be as larger as possible.
6. If the input capacitor is not allowed to be placed to the VIN and GND pins of IC as close as possible due to the limitation of component placement, at least, the bypass capacitor (C_{BP}) must follow the rule.
7. To avoid the parasitic effect of trace, the R_{SEN} should be placed to IC's VIN and SEN pins as close as possible.
8. The area, which is comprised by IC's SW pin, schottky diode and inductor, should be wide and short.
9. The path, which flows large current, should be wide and short to eliminate the parasite element.

10. When the SW is on/off, the direction of power loop should keep the same way to enhance the efficiency. The sketch is shown as figure 5.
11. To avoid unexpected damage or malfunction to the driver board, users should pay attention to the quality of soldering in the PCB by checking if cold welding or cold joint happens between the pins of IC and the PCB.
12. To stabilize the system, don't put the inductor right under the IC.

Figure 6 is the recommended layout diagram of MBI6655GSB.

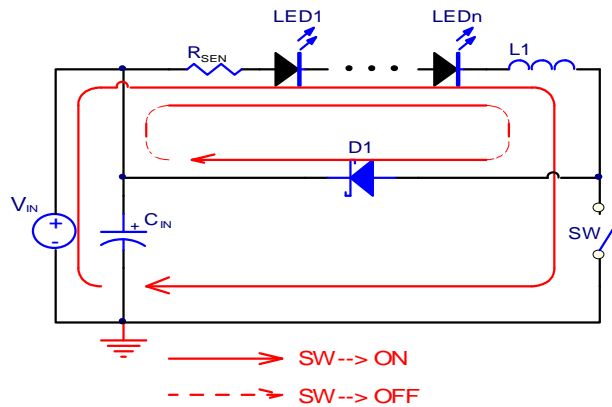
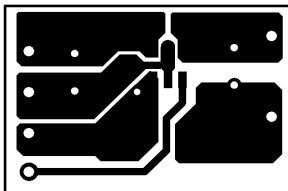
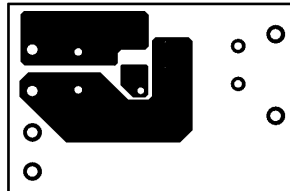

Figure 5 Power loop of MBI6655



Top layer



Bottom layer

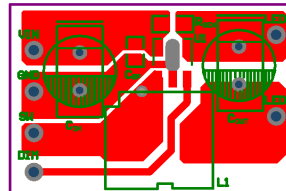

Top-Over layer

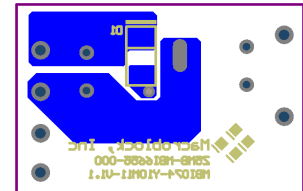

Bottom-Over layer

Figure 6. The layout diagram of MBI6655GSB